



COUNCIL POLICY

Subject: Pavement Cuts

Policy No: 05-116
Previous Policy No: 05-774
Approved by Council: 2009-06-01
Revised by Council: 2016-05-30

1. Purpose

- 1.1. To establish criteria and standards to regulate when pavement cuts will be permitted, how pavement cuts will be temporarily repaired and maintained until final restoration is completed, and to define fees and charges related to pavement cuts within Township public roadways.

2. Background

- 2.1. Utility cuts in established pavements affect the overall performance of the roadway and reduce its serviceable life and ride-ability. It is necessary that policy for pavement cuts be defined so the Township's public roadway network is maintained to ensure for safety, longevity, ride quality, and appearance.

3. Policy

- 3.1. The Municipal Engineer may issue a "Highways Use Permit" for certain uses of a public roadway that may otherwise be prohibited by Bylaw.
- 3.2. All pavement cuts must be authorized through a Township Highways Use Permit (HUP); Applicants are required to remit a permit fee as per the Fees and Charges Bylaw No. 4616 (and amendments thereto).
- 3.3. No pavement cuts are permitted on any public roadway or roadway that has been constructed or repaved within the last five years. It shall be incumbent on the permittee to satisfy the Municipal Engineer that such cuts could not be foreseen, to demonstrate that the work planned could not have been undertaken prior to the road being paved, and to demonstrate that there is no practical alternative to cutting the newly paved road. Terms for reinstatement will be at the discretion of the Township.
- 3.4. Pavement cuts on Township roads will only be permitted for work essential for the provision, maintenance and repair of the underground utilities and services where there is no practical alternative to avoid such cuts.
- 3.5. Pavement cuts, where permitted, shall be reinstated to the standards prescribed by the Township specifications (TLR 24, TLR 25, TLR 26 and TLR 27 – attached as

- Appendix “B”) as amended from time to time, which are established to ensure safety, longevity, riding quality, and aesthetics of the pavement.
- 3.6. Where a HUP has been issued for a pavement cut, the applicant will be responsible to initially replace the asphalt as per Township’s specifications and remit a non-refundable “Pavement Reinstatement Fee” for restoration work.
 - 3.7. The Applicant is responsible for the maintenance of the pavement cut(s) for a minimum of one year, or until final acceptance of the work.
 - 3.8. The Applicant is responsible to notify the Township two weeks prior to commencement of construction for inspection purposes. Where the Applicant fails to provide sufficient notice, a non-refundable “Pavement Penalty Charge” will be applied and charged to the Applicant.
 - 3.9. Where the Applicant fails to repair a utility cut when notified to do so in a timely fashion, and the Township undertakes to perform the repairs, an “Urgent Pavement Repair Fee” will be charged to the Applicant.
 - 3.10. The Township will complete the final restoration at the cost of the Applicant. In certain circumstances, where it is mutually beneficial for the Applicant to undertake the final restoration, the applicant will remit a “Pavement Degradation Fee” to compensate for the reduction in pavement life caused by the utility cuts and be permitted to make the final restoration in accordance with section 3.5 above.
 - 3.11. All costs associated with this policy including administration, inspection, and reinstatement will be offset through fees and charges established and as amended from time to time.
 - 3.12. Township staff shall coordinate and monitor the works of Utility Companies (BC Hydro, Telephone, Gas and Cable).

APPENDIX "B"

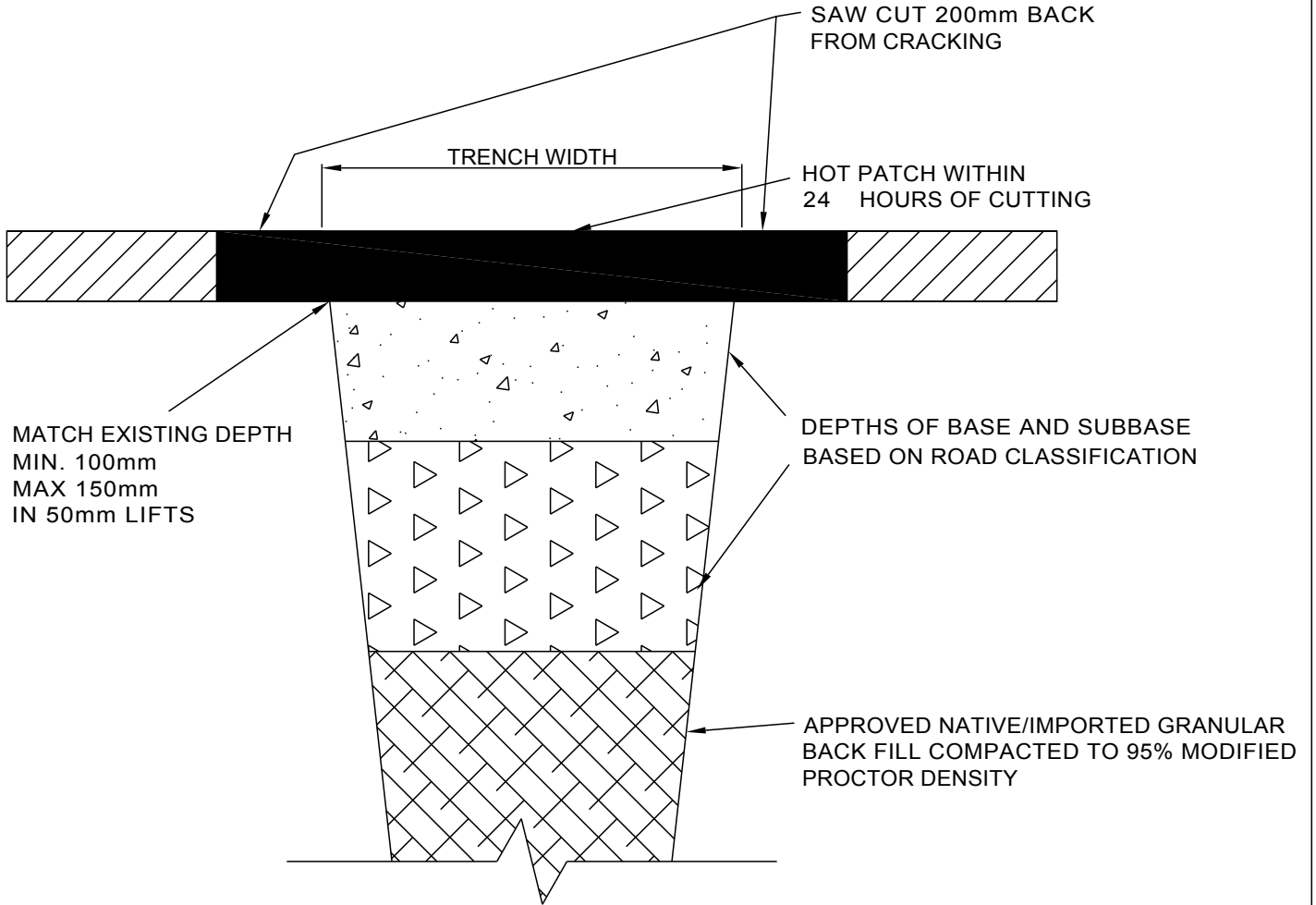

TEMPORARY
(MAX. 12 MONTHS OR AS DIRECTED BY MUNICIPAL ENGINEER*)

* MUNICIPAL ENGINEER OR THEIR DESIGNATE

NOTE: MAXIMUM 12 MONTHS AFTER SUBSTANTIAL COMPLETION OR AS DIRECTED BY MUNICIPAL ENGINEER FOR ALL LAND DEVELOPMENT PROJECTS.

TITLE

**UTILITY TRENCH PAVEMENT RESTORATION
 (LONGITUDINAL/CROSSING)**



**THE CORPORATION OF THE
 TOWNSHIP OF LANGLEY**

DATE 05/26/09

APPROVED

S.C.B.No. 0701E01.01

TLR24

APPENDIX "B"

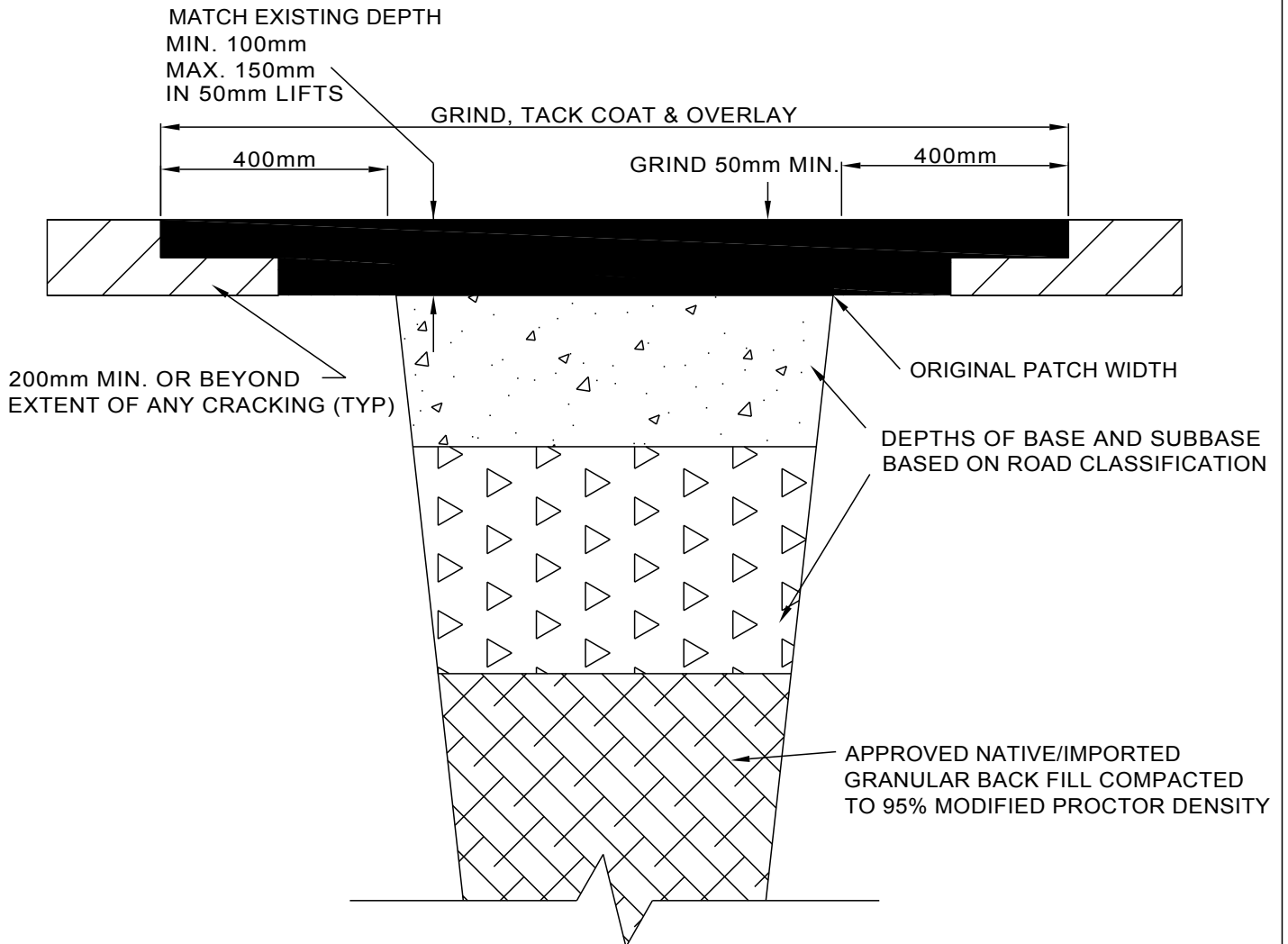

**PERMANENT
(AFTER 12 MONTHS OR AS DIRECTED BY MUNICIPAL ENGINEER*)**

* MUNICIPAL ENGINEER OR THEIR DESIGNATE

TITLE

**UTILITY TRENCH PAVEMENT RESTORATION
(LONGITUDINAL/CROSSING)**



**THE CORPORATION OF THE
TOWNSHIP OF LANGLEY**

DATE 05/26/09

APPROVED

S.C.B.No. 0701E01.02

TLR25

ARTERIAL COLLECTOR AND LOCAL ROADS

A. X-CUT

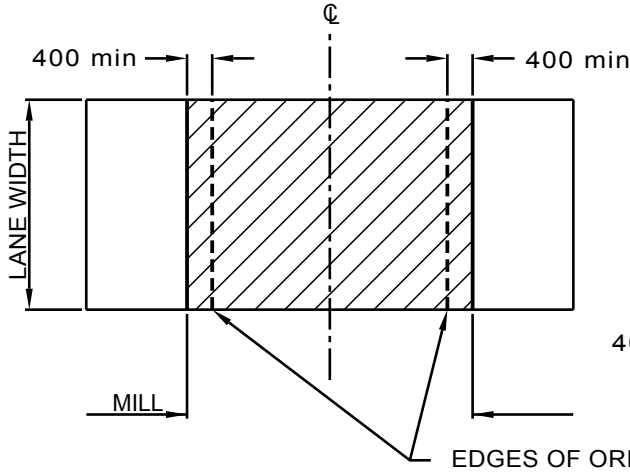

B. DIAGONAL CUT

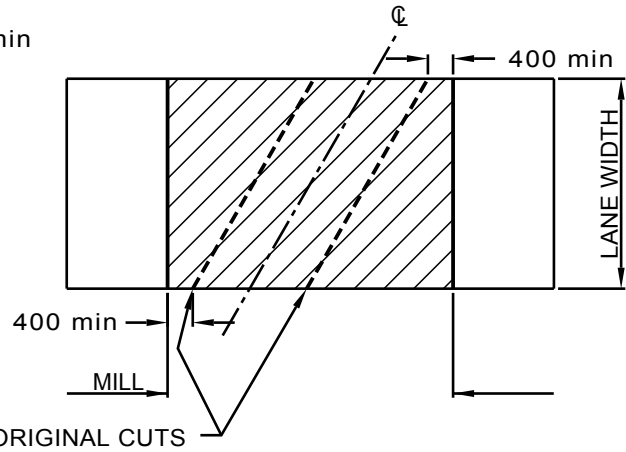

C. MULTI-SERVICE CUTS

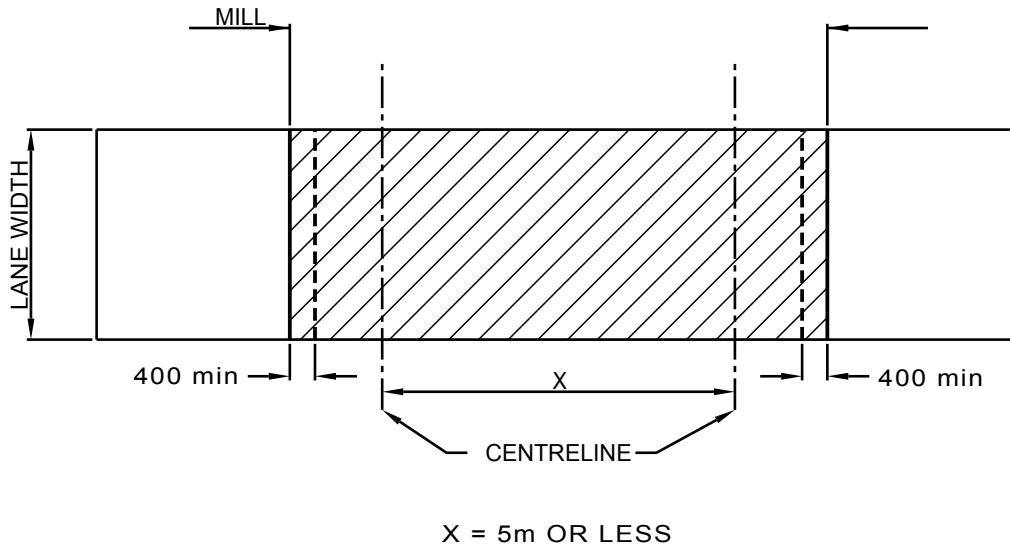

TITLE

PAVEMENT CUTTING



THE CORPORATION OF THE
TOWNSHIP OF LANGLEY

DATE 05/26/09

APPROVED

S.C.B.No. 0701E01.03

TLR26

D. IRREGULAR CUT

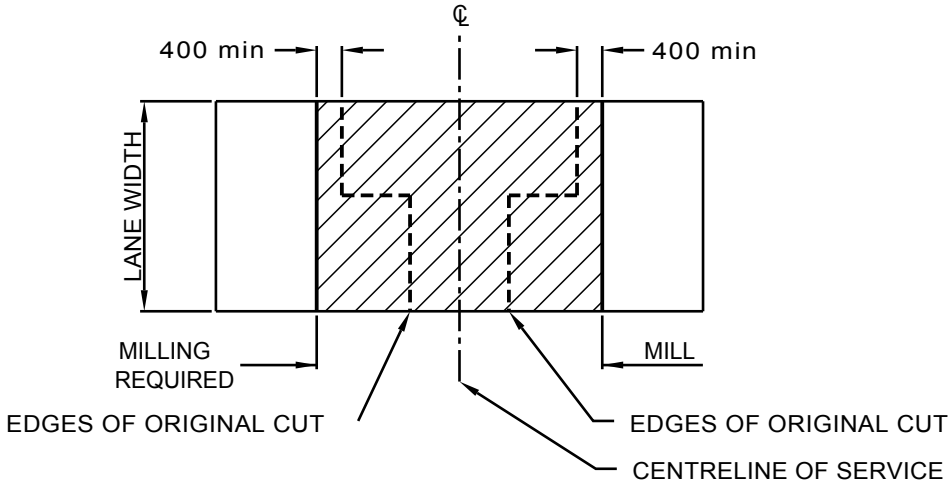

E.

ALL ROAD CLASSIFICATIONS
LONGITUDINAL CUTS

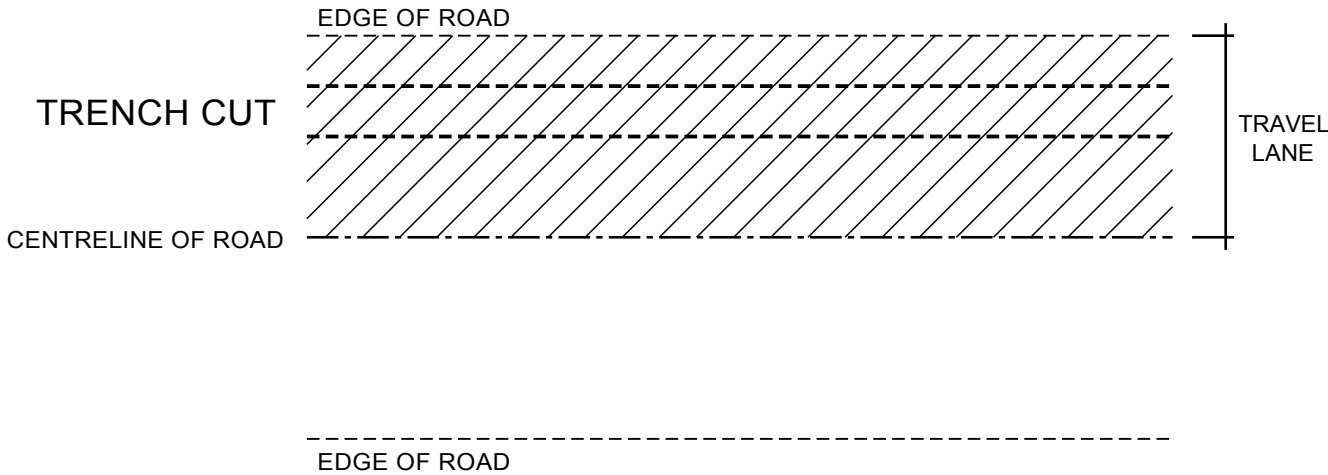

NOTES: (1) PAVEMENT DEPTH MIN. 100mm TO MAX 150mm
IN ACCORDANCE WITH STANDARD DRAWING 0701E01.02 (TLR25)

TITLE	PAVEMENT CUTTING	 Est. 1873
THE CORPORATION OF THE TOWNSHIP OF LANGLEY	DATE 05/26/09 APPROVED S.C.B.No. 0701E01.04	